

## Check Valve DF-X63



BEYOK  
OZONE GOZONE

|                        |                        |
|------------------------|------------------------|
| Construction Material: | PC body                |
| Maximum Pressure:      | 70 Kpa (10 PSI)        |
| Crack Pressures:       | 5 Kpa ( 0.7 PSI)       |
| Air Inlet Dia:         | 0.2-in (5 mm)          |
| Air Outlet Dia:        | 0.2-in (5 mm)          |
| Dimension:             | 1.4" x 0.7" (36x19 mm) |
| Net Weight:            | 0.007-lb (3.0 g)       |

The ozone check valves are an important component in preventing damage to the ozone generator. BEYOKozone valve assemblies are designed to be used in conjunction with the ozone generators to avoid back flow.

### Features:

- Ozone resistant materials
- Small size
- Inexpensive & quick installation

### Application:

- For mini ozone generator.
- Various mini air and water mixed loop for water treatment.

### Size View:

Unit: mm [ inch ]

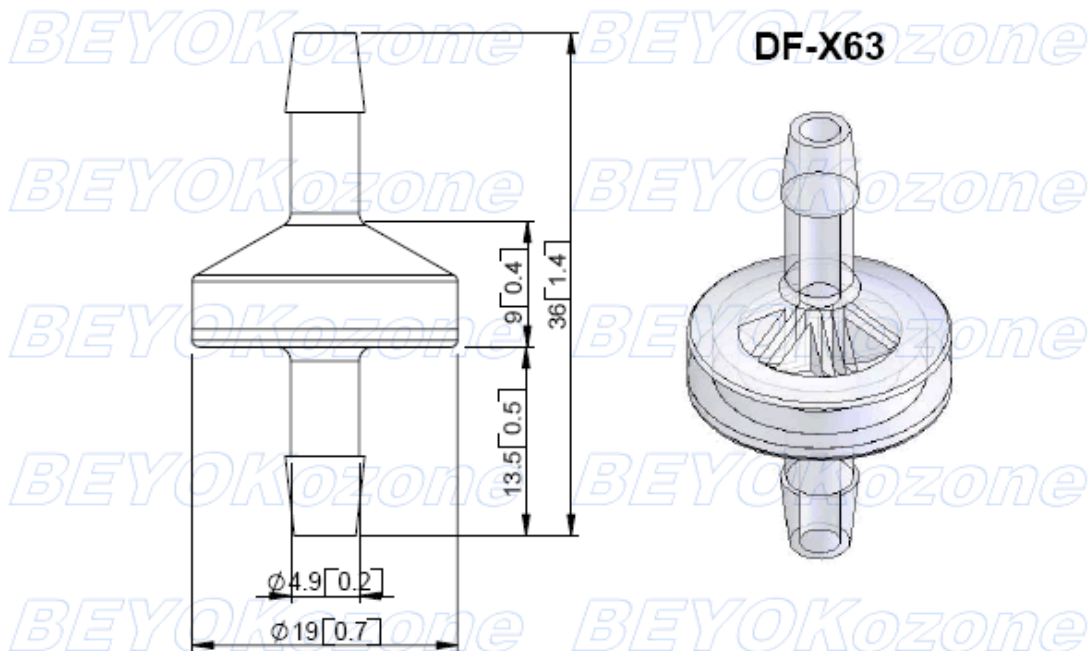

BEYOK  
OZONE GOZONE