

Wall Mounted Air Purifier **GQA-V05G**



BEYOK
OZONE COZONE

Ozone Output:	5 g/hr @ Air
Ozone Generating Method:	Corona Discharge
Electrical:	220V/50Hz-120V/60Hz, 140W
Air volume:	6 m3/min
Control:	Programmable electronic loop controller
Accessory:	Outer loop timer (optional)
Application Range:	100-200 m3
Case:	Stainless steel
Dimension(LxWxH):	23.6" *12.6"*7.1" (600*320*180 mm)
Net Weight:	- kg

The GQA-V-P series of BEYOK wall mounted air purifiers use tabular modules of high performance with built-in fans, can destroy bacteria, purify air and eliminate peculiar smell in fixed time automatically. They are suitable for food factory assembly lines, restaurants, and refrigerated storages, etc.

Features:

- Wall mounted
- Simple operation
- Can connect an external timer
- Strong ventilation
- Good dispersion
- Low cost
- Easy to maintain

Benefits:

- High efficient broad-spectrum sterilization
- Good dispersion
- Without ozone residual and secondary pollution

Application:

- Sterilization and disinfection: restaurant, hospital, packing workshop, food factory.
- Food fresh keeping: refrigerated storage.
- Deodorization: basement, garage, store room, hotel.

Size View:

Unit: mm [inch]

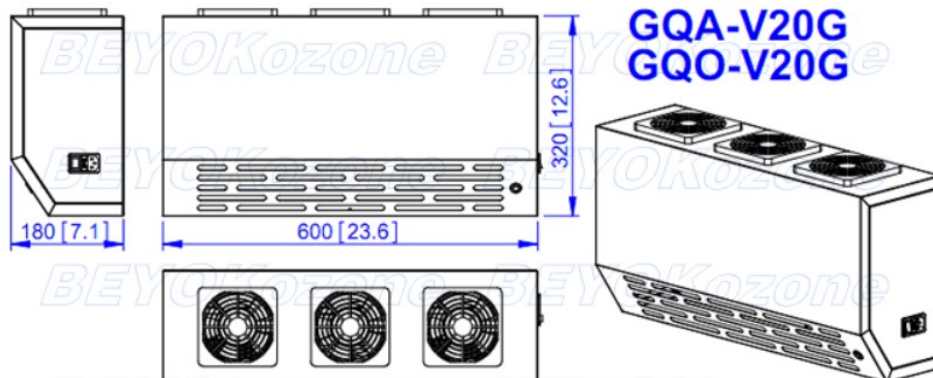

BEYOK
OZONE COZONE