

Mini Pump QB-D02



BEYOK
OZONE COZONE

Air Output:	4 SCFH (2 lpm)
Pump Pressure:	6 PSI (40 KPa)
Power Requirement:	DC12V-DC6V available
Power Consumption:	2 W
Pump Design:	Driven by DC motor
Pump Body:	Plastic
Outlet & Inlet Dia:	0.16" (4 mm)
Noise Level:	50 dB unconnected
Dimension (LxW):	1.1" *1.2" *2.4" (28*30*61 mm)
Net Weight:	0.15-lb (0.07 kg)

BEYOKozone Mini Pump MPD-24A use a DC power motor design that has the capability of over 18,000 hours of continuous maintenance-free operation. It is compact, very quiet, highly reliable and inexpensive.

Features:

- Compact size
- Steady air outputs with low noise
- Very low vibration
- Low power consumption
- Economical

Application:

- Ozone generating system
- Medical appliance
- Gas sampling

Size View:

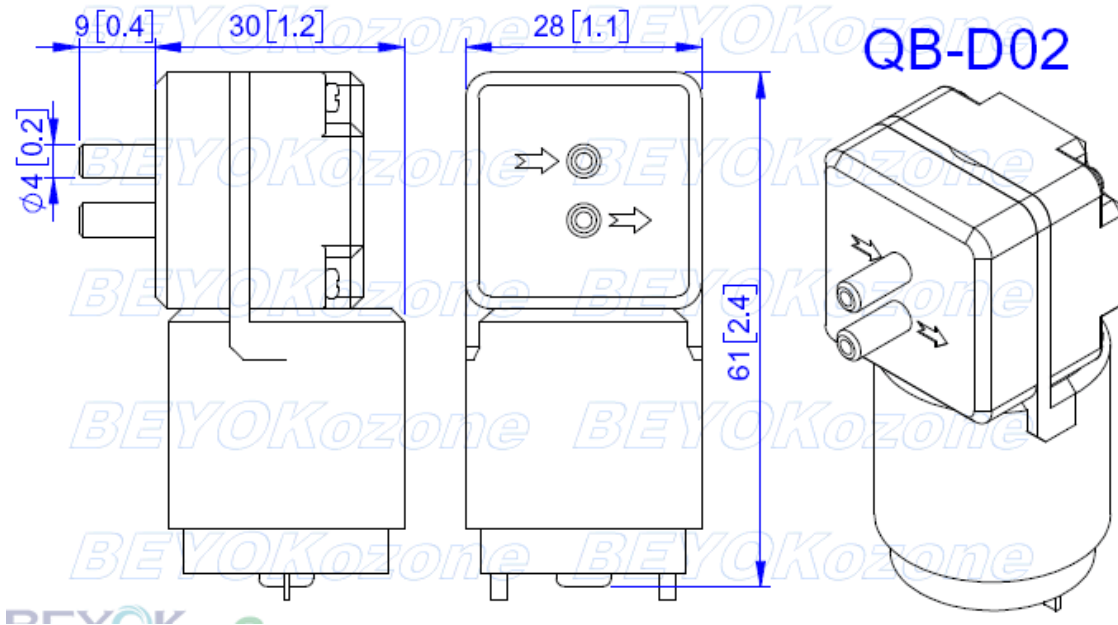

BEYOK